

# FRIALEN®-Transition Fittings HDPE/Steel USTM with internal thread PE 100 SDR 11

Maximum working pressure 5 bar (Gas)

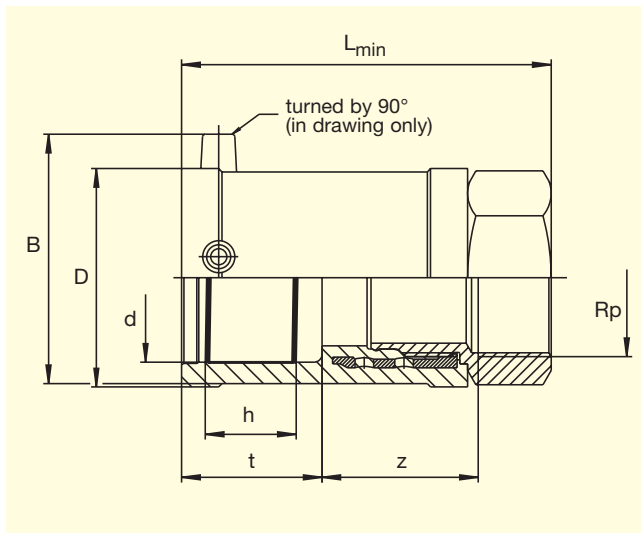

d	Rp ①	Order-Ref.	Stock-status	VE	PE	D	t	L <sub>min</sub>	z	h	B	Weight kg/each
32	1"	T-612 570	1	20	1.800	47	42	112	49	23.5	61	0.337
40	1"	T-612 571	1	20	1.000	58	45.5	121	54.5	30	69.5	0.605
40	1 1/4"	T-612 572	1	20	1.000	58	45.5	121	53	30	69.5	0.500
50	1 1/2"	T-612 574	1	15	750	70	53	136	60	29.8	80	0.650
63	2"	T-612 576	1	10	500	84	53	141	60.5	35	93.5	1.010

① Other thread sizes on request

FRIALEN®-Safety Fittings can be fused to pipes of SDR stages 11 to 17.6.  
DVGW-Registration Nos.: DV-7501AU2256 and DV-7501AU2257

Please turn over for important information regarding application of  
**FRIALEN®**-Transition Fittings USTM

# **FRIALEN<sup>®</sup>-Transition Fittings HDPE/Steel USTM**

## **with internal thread**

### **PE 100 SDR 11**

Maximum working pressure 5 bar (Gas)

#### **Areas of Application**

FRIALEN<sup>®</sup>-Transition Fittings USTM are threaded joints as an adaptor from a metal pipe with external thread to a HDPE pipe. Joint on the part of HDPE by FRIALEN<sup>®</sup>-Coupler.

#### **Assembly Instructions**

The threaded component must be held with a spanner to prevent it twisting in the HDPE component.

The fusion of the HDPE side takes place by FRIALEN<sup>®</sup>-fusing – leakproof and longitudinally strong.

The installation of the steel and the HDPE side has to be prepared according to the general installation instructions (see "Transition Fittings with threaded connection" in "Assembly Instructions" for "FRIALEN<sup>®</sup>-Safety Fittings for house connections and distribution pipes up to d 225"). This involves removing the oxide skin and cleaning the pipe ends.

#### **Eight good reasons for using the FRIALEN<sup>®</sup>-USTM**

- **Compact construction**
- **HDPE side with exposed heating element for optimal heat transfer**
- **Cold zones at the end to prevent the flow of molten material**
- **No holding clamps required**
- **Large insertion depth, extra wide fusion zones**
- **Steel end permanently anchored in the HDPE and will not distort**
- **Self sealing patented sealing geometry without elastomer seal**
- **Additional barcode for tracing back the underground fitting (Traceability-Coding).**

Please find our datasheets for downloading on the internet at [www.friatec.de](http://www.friatec.de)

**For further information, please call our FRIALEN<sup>®</sup>-customer service staff and specialist advisers.**